

– Admin Part. Consists of a multifunctional page-dashboard where the administrator can configure the application and change data about vendors, company offices, etc.

Each of the parts of the application consists of the client front-end part and the backend. The backend is built as RESTful API, and the client applications are a SPA (Single page application) application.

In order to synchronize applications with each other and ensure a unified data, used a common relational database. This allow us to interact with the same data from several parts of the applications.

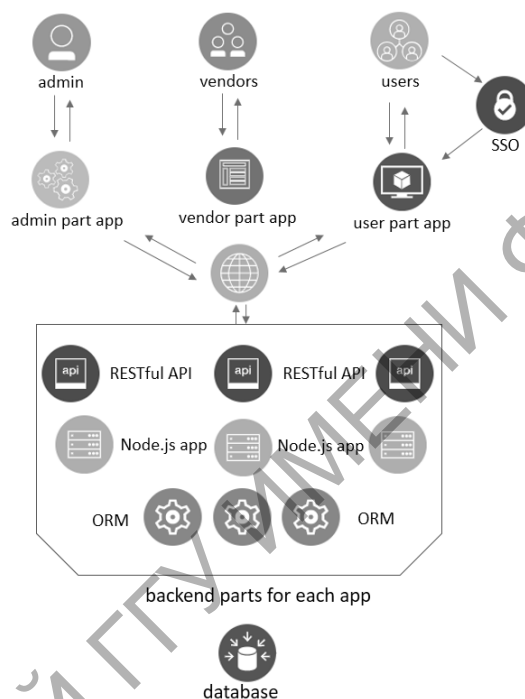

Picture 2 – Application structure

**Bunchanka Dzianis** (Fr. Skorina GSU, Gomel)

Scientific advisor **Viktar Liauchuk**, Ph.D. in technics, associate professor

## **APPLICATION ARCHITECTURE FOR MONITORING THE IMPLEMENTATION OF ROUTINE MAINTENANCE**

Scheduled works are an effective means of maintaining the reliability of vehicles.

High quality and short terms of performance of routine works on any type are provided by using the most advanced planning methods (network linear schedules), rational distribution of specialists, ensuring a high load factor for each and completing work on all specialties in a single term.

The main idea of the project is to provide user with ability of manipulating car services data.

Nowadays users can find few internet-services, which provide any abilities of car maintenance, such as “Penta”, “Car Rental”, “Accounting And repair of vehicles”.

Programs, described above, have several disadvantages. Frist of all they are heavyweight and require several programs to be installed on client-side (like ‘1-C’).

Those programs and program decisions do not have decent architecture and have bad user interaction or do not have it at all.

The main idea of project is to make a good and best-looking application using modern programming languages and frameworks in order to achieve the best user experience and to make decent browser-application.

In this case, project is made using JavaScript language. It is one of the most popular and powerful language with browser and HTML-interaction.

In addition, I used modern and powerful JavaScript framework called React. It helps to make useful interaction via one-side data flow and has the idea of the components, which helps to make soft and handy application for user.

Above that, I used NodeJS. This is server-side JavaScript, which helps to make a strong back-end side of the application. It also contains Node Packet Manager to control many packages to maintain application.

I had several develop stages during the implementation of manipulating car services data:

- a) Implementation of precedent diagrams and basic scenarios.
- b) Structuring of the main data flow.
- c) Making basic application.
- d) Managing connection between application and database.
- e) Finalizing main API and UI structure.

Main workflow and actions consists of several steps: user logs into system, then he makes different data actions (like adding, editing, removing information) changes applies to the data base via JSON format, data base refreshes and gives updated data. (Picture 1)

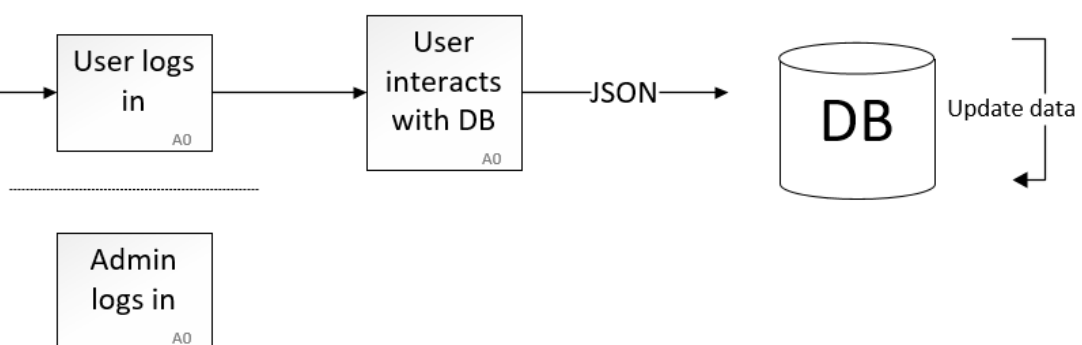

Picture 1 – Main data flow

Database contains several tables: User, Car works, Services and Admin.  
(Picture 2)

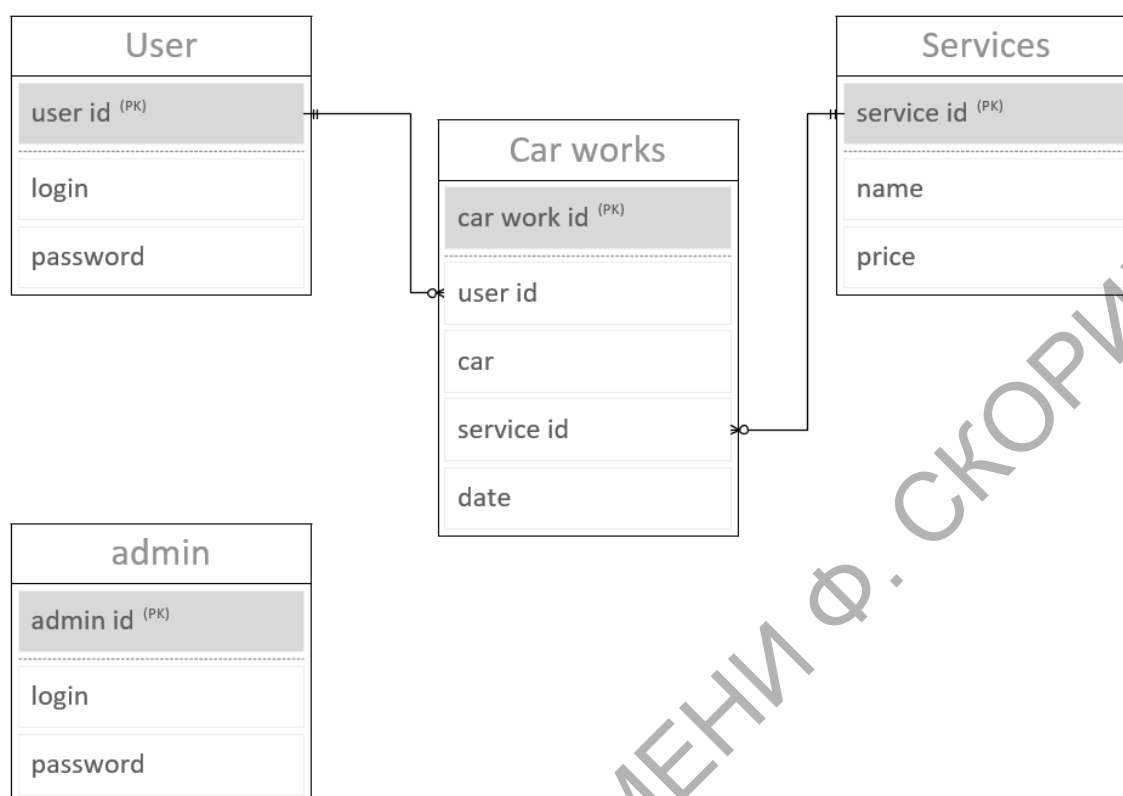

Picture 2 – Project Data Base

**Bunchanka Dzianis** (Fr. Skorina GSU, Gomel)

Scientific advisor **Viktar Liauchuk**, Ph.D. in technics, associate professor

## DEVELOPMENT OF AN APPLICATION FOR MONITORING THE IMPLEMENTATION OF ROUTINE MAINTENANCE

In order to make modern, reactive and powerful web-application, it is necessary to use modern technologies and frameworks. So my application was made with the help of one of the most popular and reliable technologies.

I will describe main functional abilities of the most useful of them.

JavaScript, often abbreviated as JS, is a high-level, dynamic, weakly typed, prototype-based, multi-paradigm, and interpreted programming language. With the help of JS I've manipulated the main data-flow of the front-end part such as user lists, arrays of cars and maintenance prices. ES6 (ECMA Script) is a standard of JS which provides 'syntax sugar' to build separated classes and define scoped variables. With ES6 I've made classes such as User, Car, Admin, Order, and PriceList.

In computing, React (sometimes styled React.js or ReactJS) is a JavaScript library for building user interfaces.